

# U.S. TSUBAKI SHOCK RELAY

## TSB151, TSB152

### Shock Relay for Overload Protection

#### ACTUAL LOAD METER

Actual current of the motor is indicated in percentages, which makes it easy to set "LOAD CURRENT," regardless of the value of the actual current load.

#### LOAD CURRENT

This presets the load current at the optimum setting in the range from 30% to 130% of the motor's current. When the actual load current exceeds the preset current for the preset SHOCK TIME, the SHOCK RELAY trips to break the motor circuit. Audible alarm devices or warning lamps may be installed if desired.

The LOAD CURRENT should be preset by observing the ACTUAL LOAD METER condition because the motor generally runs under its rated current value.

#### FINE ADJUSTMENT

Adjustment is preset at the factory. When fine adjustment of actual load current is required, this may be used to adjust from -5% to +30% of the indicated meter value.

#### START TIME

When starting a motor, the starting current value is greater than the running current. This starting current value continues until the motor reaches normal speed. During this starting period, the time of which mainly depends on the type of load, the function of detecting the overload current is disabled. Adjustable range is from 0.2 to 20 seconds.

#### TERMINALS FOR CONNECTION

All terminals are located on the upper surface to provide easy access.

#### POWER INDICATOR

Indicates that the power supply is on.

#### TRIP INDICATOR

Lamp comes on when SHOCK RELAY trips.

#### TEST BUTTON

This switch is used to verify SHOCK RELAY operation.

#### RESET BUTTON (manual)

Reset can be done quickly whenever a cycle restart is desired.

#### SHOCK TIME

This presets the overload period. Range is variable from 0.2 to 3 seconds. Every momentary load over the preset current with a shorter period than the preset period is ignored. When the overload equals the preset period, the SHOCK RELAY will trip immediately to break the power supply to the motor.

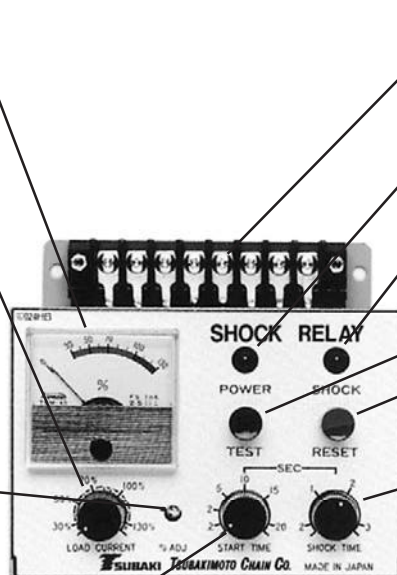

U.S. Tsubaki SHOCK RELAY monitors the change in motor current that closely approximates the torque output of the motor. Should the motor current exceed the preset LOAD CURRENT point for a preset length of SHOCK TIME (continuous overload time), the SHOCK RELAY will shut down the motor power supply.

#### DIAGRAM OF OPERATION

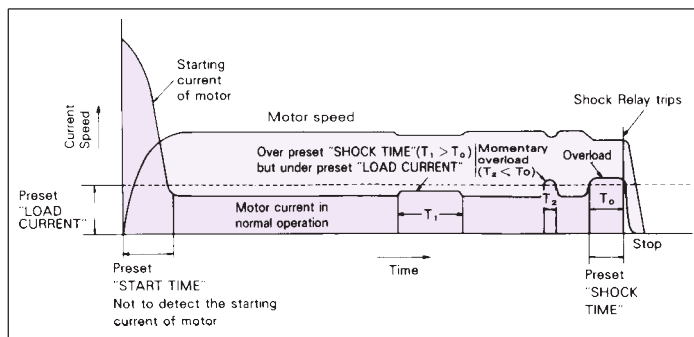

#### TYPICAL CONNECTING DIAGRAM

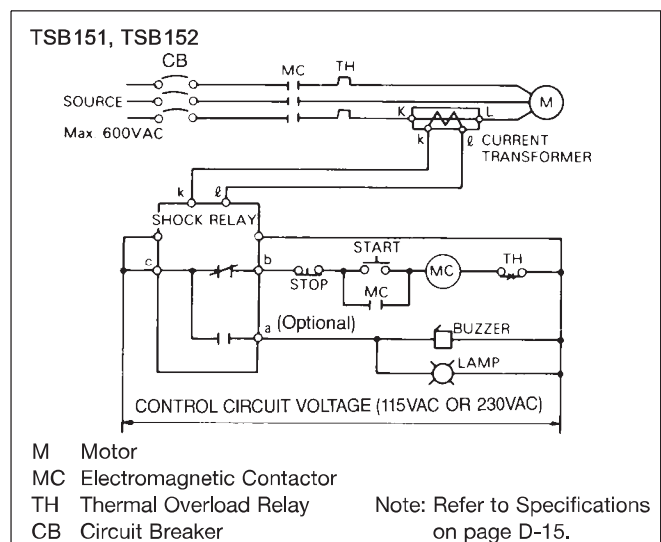

D - PT COMPONENTS

The TSB151 and TSB152 series SHOCK RELAY allows easy connection into new or existing applications. For single or three phase motors, simply wire the current transformer that we supply into one line of the motor and the SHOCK RELAY into the control circuit (stop-start circuit).

The SHOCK RELAY is powered by the same voltage as the control circuit to the motor starter, usually 115V or 230V single phase. If a different control voltage is used, a step down transformer may be required.

The supplied current transformer is then connected in one line of the motor that is being monitored. Motor voltages above 600 volts require special considerations. Contact U.S. Tsubaki.

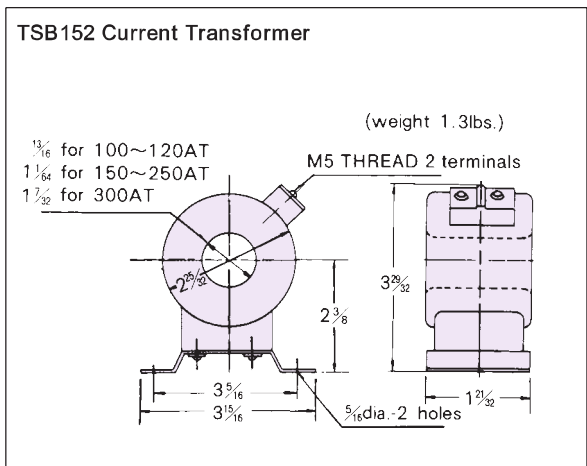
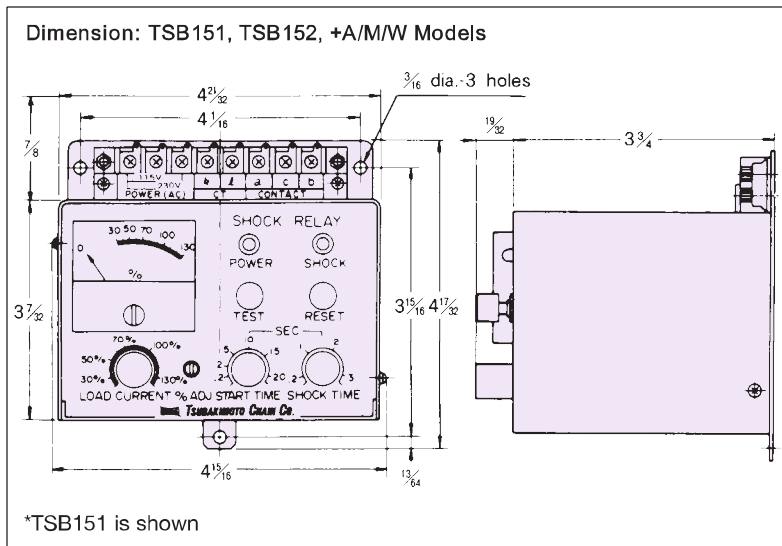

For use with TSB152, TSB152A, TSB152M, TSB152W

When ordering the TSB152, please select the correct size current transformer from the chart below. The transformer selected should closely match the motor amperage. U.S. Tsubaki will include the transformer you select with the TSB152 Shock Relay.

Current Transformer for TSB152			
Full-Load Current (amps)	Selected CT	Full-Load Current (amps)	Selected CT
20	100AT	83	250AT
25	100AT	100	100AT
30	120AT	120	120AT
33	100AT	125	250AT
37	150AT	150	150AT
40	120AT	200	200AT
50	100AT	250	250AT
60	120AT	300	300AT
		400	400AT

When selecting a Shock Relay and compatible Current Transformer, locate the closest rating to the actual motor current in the list.

**Selection Example**

- For 4 pole, 230V, 7½HP motor: rated current 21.5 amps, choose TSB152, 100AT current transformer.
- For 4 pole 230V, 50HP motor: rated current 124 amps, choose TSB152, 250AT current transformer.

